



Assembly Instruction

ITEM#: 1718NGYK EASTERN KING BED
 1718NGYK-1 EASTERN KING HEADBOARD
 1718NGYK-2 EASTERN KING FOOTBOARD & SLATS
 1718NGY-3 EASTERN KING BED RAILS

PART LIST

1	HEADBOARD	1PC
2	HEADBOARD POST LSF	1PC
3	HEADBOARD POST RSF	1PC
4	FOOTBOARD W/DRAWER	1PC
5	BUN FOOT	2PCS
6	SUPPORT LEG OF DRAWER	3PCS
7	SUPPORT LEG OF SLAT	10PCS
8	SLAT	1ROLL/13PCS
9	RAIL	2PCS

HARDWARE LIST IN -1

A		BOLT Ø5/16"x1 1/2"L	6PCS
B		SPRING WASHER Ø1/2"xØ5/16"	6PCS
C		FLAT WASHER Ø3/4"xØ5/16"	6PCS
D		ALLEN KEY 5/16"	1PC

HARDWARE LIST IN -2

E		SCREW#8x1-1/4"	14PCS
---	--	----------------	-------

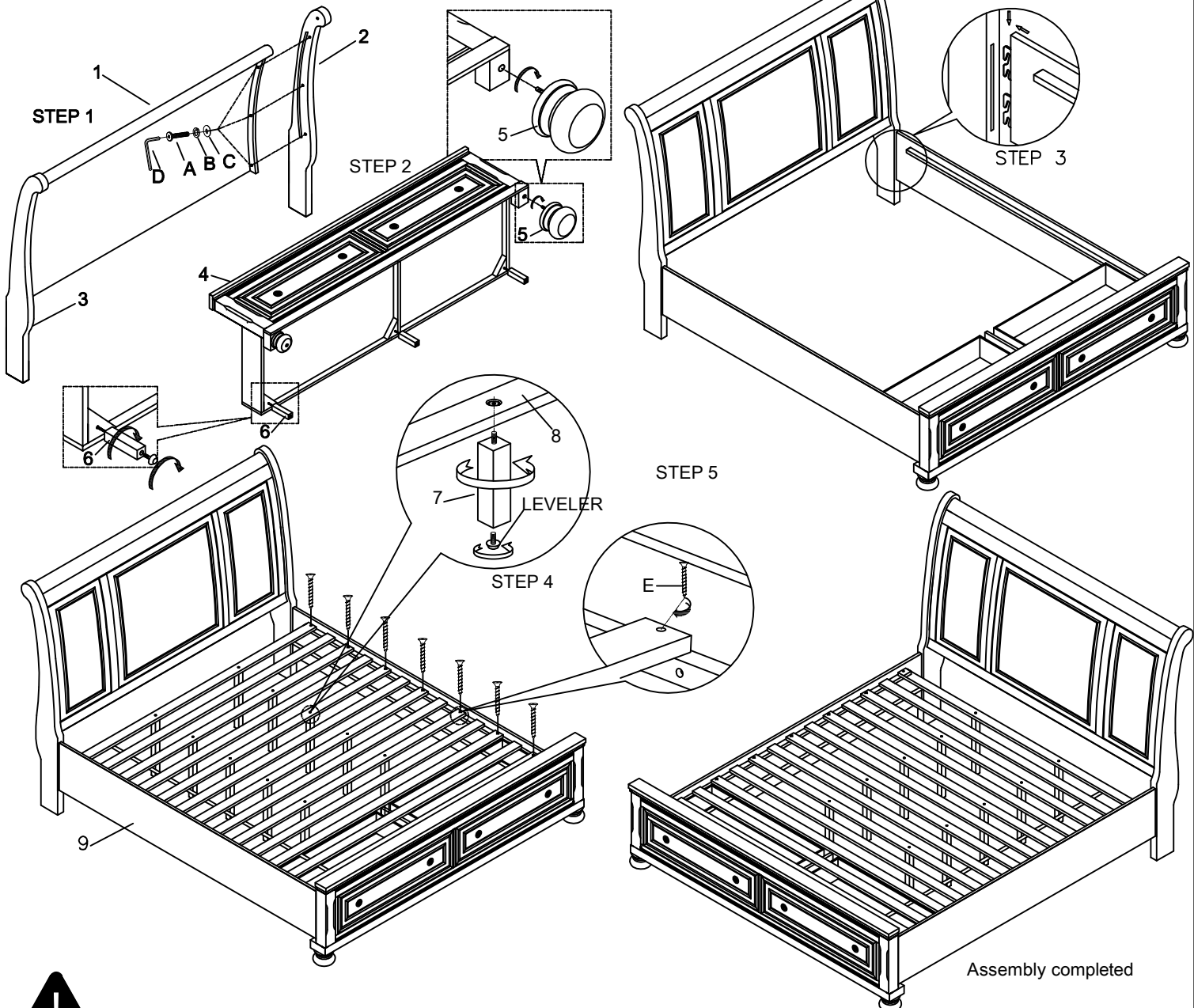

For items use on wooden floor hard surfaces or carpets it is recommended to install protective pads under all legs and supports to avoid/prevent from damages/scratches and discoloration

MADE IN VIETNAM